



Determining the Causes of Punching Shear in Reinforced Slabs Using Fishbone Diagram

Abbas M. Burhan ^{a*}, Meervat R. Altaie ^a, Omer K. Al-Kubaisi ^{a, b}

^a Civil Engineering Department, University of Baghdad, Al-Jadryia, Baghdad 10071, Iraq.

^b School of Civil Engineering, The University of Sydney, Sydney, NSW 2006, Australia.

Received 14 July 2018; Accepted 15 October 2018

Abstract

Risk identification and assessment can be analysed using many risk management tools. Fishbone diagram is one of these techniques which can be employed, for the identification of the causes behind the construction failure, which has become a phenomenon that often gets repeated in several projects. If these failures are not understood and handled scientifically, it may lead to disputes between the project parties. Additionally, the construction failure also leads to an increase in the project budget, which in turn causes a delay in the completion of the projects. Punching shear in reinforcement slab may be one of the reasons for construction failures. However, there are many doubts about other causes that lead to this failure as well as the role of these causes in the construction failure. Also, there are many causes linked to this failure of which some fall on the designer and the others fall on the contractor. Thus, this research aims to determine the causes of punching shear failure in the concrete slab and its role in the failure using a logic managerial analysis. For this purpose, the applicability of the Fishbone diagram has been extended, for the analysis of probability as well as the impact of the risk of punching shear, thus elucidating the risk score of each category without ignoring the global risk. In this direction, interviews and questionnaires are conducted with numerous experts specialize in both the design and execution field of construction projects for identifying the most important causes that lead to the occurrence of punching shear failure. Further, the Fishbone diagram for punching shear's risk illuminated that impact of some of the primary and secondary causes such as planning, designing, and maintenance is more than the expectation. Therefore, the concentration in these areas should be carried out by taking into consideration the adapt risk response plan to prevent or mitigate these risks.

Keywords: Fishbone Diagram; Global Risk; Weight; Probability; Impact.

1. Introduction

Usually, the defects in construction projects leading to its failures provoke the dispute between the project parties. These disputes in construction projects, if not solved timely, become very expensive – regarding time, personnel, finances, and opportunity costs [1]. Punching shear problem is one such expensive defect, which may need a costly decision thus requiring the demolition of the building. So, the current research attempts to present managerial analysis to determine the probable reasons that are responsible for the occurrence of the punching shear problem, thereby giving an indication to the decision makers and project parties that any construction defect must be analyzed scientifically to avoid the disputes between the project parties.

In the current investigation, only flat slabs were taken into consideration, as this type of structure comes up with easier installation, thereby enabling better usage of room height as compared to slabs supported by beams. Nowadays, many buildings such as car-park buildings use this type of system. But, the main disadvantage of this type of slab is the

* Corresponding author: abbas_alshemosi@yahoo.com

 <http://dx.doi.org/10.28991/cej-03091188>

➤ This is an open access article under the CC-BY license (<https://creativecommons.org/licenses/by/4.0/>).

© Authors retain all copyrights.

nature of contact surfaces present between the slab and the columns. In general, these connections are in association with small and high stress, which upon reaching a certain limit might fail in a mode called punching shear [2]. The first signs of cracking become obvious, above the columns on the upper slab surface, when the tensile strength of the concrete reaches maximum. Thus, the column cracks, radially, in the outward direction. As the load increases further, the tangential cracks also appear around the column. Finally, upon occurrence of the failure, an inclined inner shear crack undergoes breakage through the slab. At this point, the column punches out a conical shaped slab portion bounded by this crack. This type of shearing is, termed as punching shear, which is usually a brittle and sudden type of failure [2].

Fishbone diagram also called as 'cause-and-effect' diagram, is a tool used to identify the root cause of construction failure problems, thereby elucidating the effect and the factors or causes influencing it. This tool is a template for brainstorming possible causes of repercussions. Since there could be infinite causes, this helps in identifying the root cause/s in a structured and precise way [3].

Many researchers have used the Fishbone diagram to estimate the risk of an effect on their projects. For example, Luo et al. [4] have studied the implementation of Fishbone diagrams in the assessment of natural gas tank's safety. They used the improved Fishbone diagram to analyze all the reasons that may cause leakage in spherical gas tanks and found that the Fishbone diagram was efficient to make a quantitative study. Similarly, Wang [5] has discussed the use of the fishbone diagram for controlling the quality of steel structure installation projects. Likewise, Niu et al. [6] presented a study based on the fishbone diagram for the identification of the cost risk factors in power grid construction projects considering, according to the project construction process, project decision-making and feasibility study phase, design and bidding phase, construction phase, and completion of final accounts and summary evaluation phase of the projects.

In this research, the punching shear, which occurred in a building of Baghdad after its completion (as shown in Figure 1), was taken into consideration as the case study to implement Fishbone Diagram Technique. The "Punching Shear" can be considered, as one of the shear failure types that occur in reinforced concrete slabs in which the column penetrates into it due to the high localized forces as shown in Figure 2 [2]. Further, it can happen in flat slabs due to an increase in the weight of the structure or the applied loads on the structure. Since this type of construction failure exhibits no visible signs before the failure, they are believed to be catastrophic by nature. Usually, some financial issues are allied with the catastrophic failure. So, if the causes responsible for the occurrence these failures are not identified, disputes may arise between the project parties, which may further proceed to the court. Nevertheless, the study of the reasons behind the failure takes into account the situation when a decision from the specialists, is required. Therefore, this study attempts to present a managerial system to track the causes of construction failure by using the fishbone diagram because the tracking of problem causes is a part of the problem-solving process.

The present investigation aims to apply the fishbone diagram to track the causes of punching shear failure in flat slab. Subsequently, a quantitative analysis was carried out to find the impact of causes and sub-causes. The idea originated when a building in Baghdad suffered a punching shear problem (as shown in Figure 1). Thus, an assessment was required to determine the causes leading to this problem and identifying the responsible party for it. So, the tracking of the reasons behind the issue, thereby estimating its impact can lead to the development of a successful management tool for the consultant team tasked with fact-finding.

Several limitations are given for this study as follows:

- The study only treated the punching shear in the flat slab.
- The focus of the research work was only on the investigation of the causes, root-causes, and the impact of these causes leading to punching shear failure in a building of Baghdad. Hence, no deep analysis of the details related to the behavior of shear reinforcement, tests, and the types of punching shear failure was carried out.

2. Research Methodology

The researcher conducted personal interviews with several experts, specialize in design and execution fields for the construction projects, for determining the most vital causes that lead to the occurrence of punching shear failure in the reinforced flat slab. Since the personal interview is an information gathering technique to elicit ideas on the causes of punching shear failure from experts, the collected reasons were further analyzed using one of diagramming techniques. For this purpose, the Fishbone diagram (also known Ishikawa or cause-and-effect diagram), was selected as it tracks down the core cause of the risk. Subsequently, quantitative assessment to the risk was carried out using simulation for the failure that had occurred, which aided in the calculation of the risk score for each cause. Thus, the factors responsible for the failure were arranged based on their risk score, which in turn enabled in the identification of the core cause of the occurrence of the problem as well as the responsible party. Therefore, one should concentrate on these causes to adopt the risk response plan for preventing or mitigating these risks for future projects.



Figure 1. The punching shear failure in the case study (building in Baghdad)

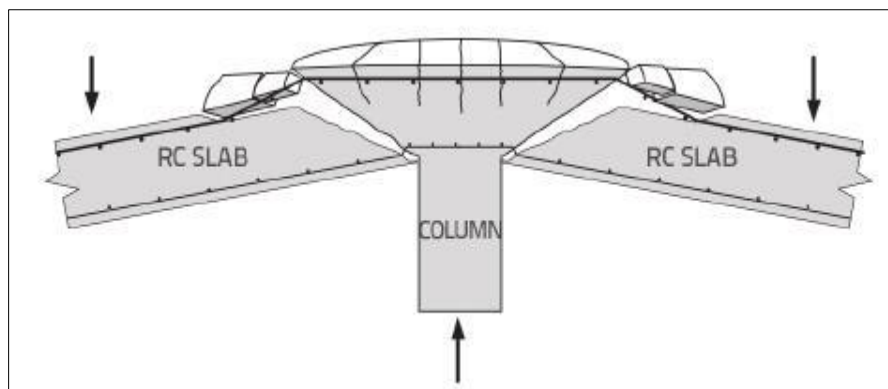

Figure 2. Punching shear failure in a flat slab [2]

3. Punching Shear Failure in Reinforced Flat Slab

Punching shear failure is a phenomenon that may occur in reinforcement concrete slabs (flat type) caused by concerted support reactions, which induces a cone-shaped perforation starting from the top surface of the slab. Although, in general, preceded by flexural failure, punching shear is a brittle failure mode and the risk of progressive collapse requires a higher safety class in the structural design [7]. It occurs when the column punches through the slab, and it can be characterized by the truncated or pyramid failure surface. This type of failure is extremely dangerous and should be prevented, since it may lead to brittle, with little or no warning, and progressive collapse of floors. Possible failure modes of flat slab with punching shear are a) crushing of compression strut; b) failure within the region of the shear reinforcement; and c) failure outside the shear reinforced zone [8]. Several researchers have also studied this punching shear failure. For instance, Belletti et al. [9] studied the punching shear failure using approximation approach. They used the *fib* model code 2010 to estimate the punching shear resistance using two different approaches, which further

underwent comparison with the experimental results. Moreover, Ju et al. [10] studied the prediction of punching shear failure using probability-based approach. They suggested a new formula for predicting punching shear of reinforced concrete flat slabs.

4. The Responsibility of Punching Shear Failure

The construction failures have become a phenomenon that often recurs in several projects of Iraq. Therefore, it is essential to establish the factors responsible for the occurrence of the breakdown since sometimes disputes between project parties arise regarding detection of the party responsible for the construction failure. Also, the construction failure leads to an increase in the project budget, which in turn may lead to a delay in the completion time. Further, it is stated that punching shear in reinforcement slab may be one of the reasons for the failure of the construction. However, there are many questions about the factors responsible for this failure along with their role in the breakdown. Additionally, there are many causes linked to this failure of which some fall on the designer and few make the contractor responsible for the collapse. Thus, this research aims to determine the causes of punching shear failure in concrete slab by using a logic managerial analysis.

Typically, the defects in the construction projects, followed by their failures lead to the occurrence of dispute between the projects parties, which if not resolved timely, become very expensive regarding time, personnel, finances, and opportunity costs. Punching shear problem is one of the priciest defects which may need a costly decision reaching up to the demolition of the building. Thus, this research attempts to determine the probable causes that led to the occurrence of the punching shear problem using managerial analysis, thus giving an indication to the decision makers and project parties that all construction defects must be analyzed at scientific level to avoid the disputes between the project parties.

5. Problem Analysis

Problem analysis undergoes division into two main categories: (a) analysis of the problem, and (b) causes codification.

5.1. Analysis of Problem

In the very first step of the analysis of the problem, a simulation was carried out for the failure that had occurred. There are several doubts associated with the construction breakdown such as (a) what is the failure that occurred? (b) Where it happened?, (c) when it happened? and (c) why it happened?. Thus, the analysis must throw some light on these questions. Upon examining the case study, the answers to these queries are as follows:

- i. In response to the first question, which talks about the problem occurred, the punching shear has been recognized, as the one of the issue associated with the failure.
- ii. The second question asking about the place of the occurrence of the failure is answered, by mentioning that a building in Baghdad underwent the collapse.
- iii. The third question, which asks about the stage of the construction when this breakdown occurred, is replied by stating that the building collapsed after its completion.
- iv. The fourth question, which inquires about the factor responsible for the failure, is answered back by pointing out that the core cause yet to be identified by using the Fishbone Diagram.

To determine the Fishbone diagram for punching shear, the four main reasons have been distributed to the left and right (up and down) of the horizontal axis based on two categories: (a) the conditions of the activity (planning and designing factors), and (b) the management of the project (executing and operation and maintenance factors). Furthermore, the secondary causes have been distributed along the axis of the core causes as shown in Figure 3.

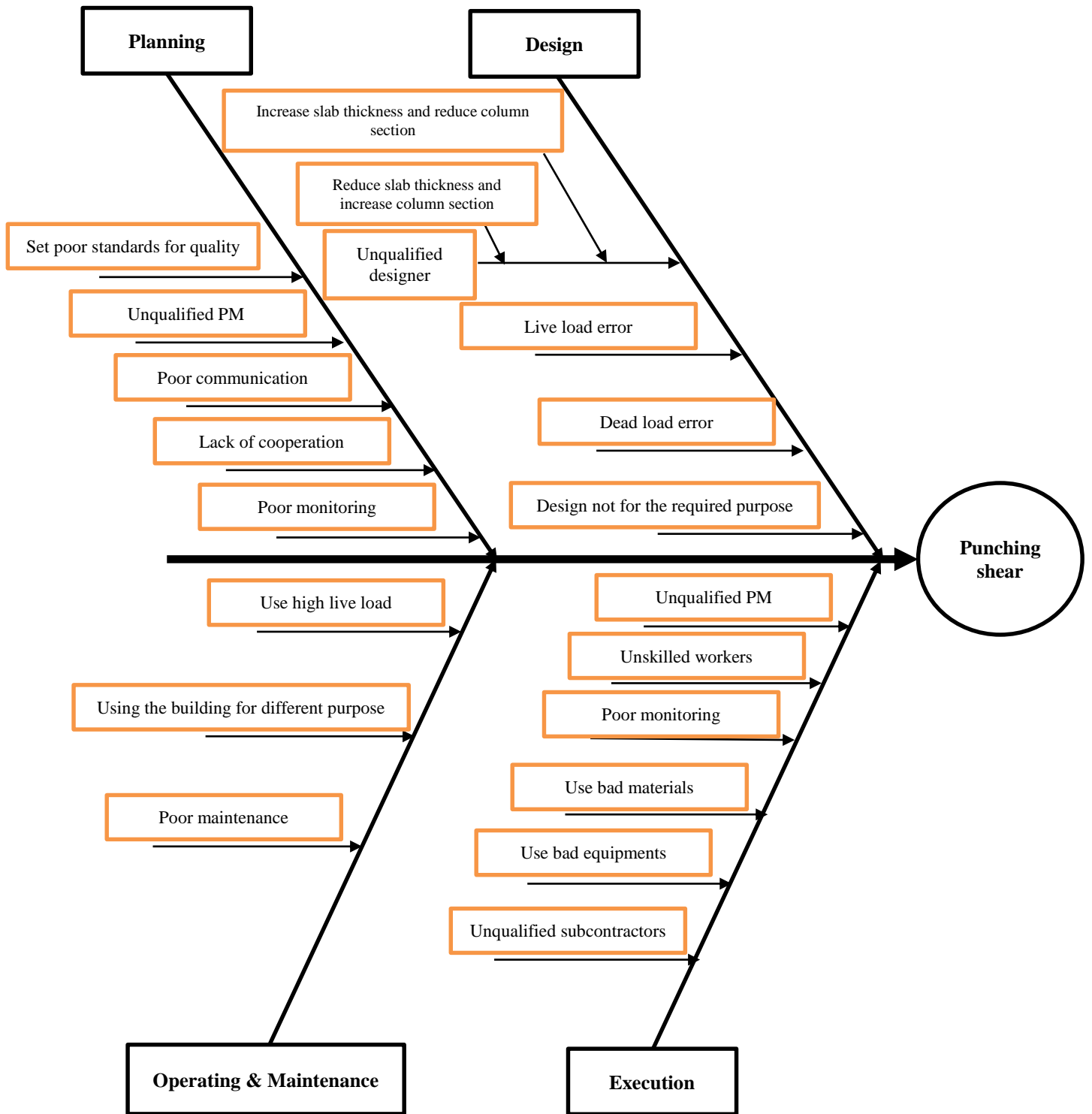

Figure 3. Fishbone diagram for punching shear

5.2. Cause Codification

As shown in Figure 3, four main reasons, related to design, planning, execution, and operation and maintenance, were identified. Apart from this, there are twenty sub-causes associated with the main causes. Further, to use the Fishbone diagram properly causes codification had been proposed for both primary and secondary causes as shown in Table 1, which facilitates the qualitative assessment for all causes.

Table 1. Causes codification

Current issue	Main Cause	Sub-Cause	Sub-Sub cause	Code
1	Planning			L1
1.1		Unqualified PM		L11
1.2		Poor communication		L12
1.3		Uncooperative project team		L13
1.4		poor monitoring		L14
1.5		Set poor standards for quality		L15
2	Design			L2
2.1		Live load error		L21
2.2		Dead load error		L22
2.3		Design the building not for the same required purpose		L23
2.4		Unqualified designer		L24
2.4.1			Using a high roof thickness and reduce the column section	L241
2.4.2			Using a little roof thickness and Increase the column section	L242
3	O&M			D1
3.1		Poor Maintenance		D11
3.2		Use the building not for the Purpose for which it was designed		D12
3.3		Use a high live load		D13
4	Executing			D2
4.1		Use bad equipment		D21
4.2		Use bad materials		D22
4.3		Unskilled workers		D23
4.4		Unqualified PM		D24
4.5		Poor monitoring		D25
4.6		Execute the work by unqualified subcontractors		D26

6. Global Risk Assessment

Global risk of an effect can be defined as the sum of the weights of the main causes risk as shown in Equation (1).

$$Risk (R) = \sum_{i=1}^n Probability\ of\ the\ Risk (P_i) \times Risk\ weight (R_i) \tag{1}$$

Based on this definition, the punching shear’s risk (R_g) can be calculated by summing the risk of the categories on the left (R_l) and on the right (R_d) of the horizontal axis as shown in Equation (2).

$$R_g = P_l \times R_l + P_d \times R_d \tag{2}$$

Where P_l and P_d are the probabilities of the risk weight on the left and right respectively. The sum of both P_l and P_d should be equal to 1.

In turn, each risk is a weighted sum of the main causes of the risks distributed to the left or to the right:

$$R_l = \sum p_i \times R_{li}; \sum P_i = 1,$$

And R_{li} are the main causes distributed to the left and

$$R_d = \sum p_j \times R_{dj}; \sum P_j = 1,$$

And R_{dj} are the main causes distributed to the right.

Also, each risk of a main cause represents the weighted sum of the risks of the secondary causes which determine its existence (the effect):

$$R_{li} = \sum P_{ik} \times R_{lik}; \sum P_{ik} = 1$$

And, Rl_{ik} represent the risk of the secondary causes which determine the existence of main causes to the left;

$$Rd_j = \sum P_{jl} \times Rd_{jl}; \sum P_{jl} = 1$$

And Rd_{jl} represent the risk of the secondary causes which determine the existence of main causes to the right.

The global risk can be determined according to the following algorithm based on tables or direct formalizations:

- Evaluate or determine risks of secondary causes (Rl_{ik} and p_{ik} ; Rd_{jl} and p_{jl}), using any method which can conduct to plausible results and, obviously, the appropriate formalization;
- Determine risks of main causes as weighted sums of the secondary causes risks and evaluate or determine their weights inside the category they belong to (Rl_i and p_i ; Rd_j and p_j);
- Determine risk categories by causes (Rl and Rd) and evaluate or determine their weights in the global risk (p_l and p_d);
- Determine the global risk (R_g) of the effect (event).

Table 2 contains the weight of each main and secondary category of punching shear causes and for more explanations for these weights, Figure 4 is prepared.

Table 2. The weights of main and secondary causes

Current Issue	Code			Weights Of Sub-Cause	We. Control	We. Of Main Cau.	We. Control	Effect Wei.
	Main Cause	Sub-Cause	Sub-Subcau.					
1	L1							
1.1		L11		0.30				
1.2		L12		0.10				
1.3		L13		0.10	1	0.30		
1.4		L14		0.35				
1.5		L15		0.15				
2	L2						1	0.68
2.1		L21		0.25				
2.2		L22		0.25	1			
2.3		L23		0.20		0.70		
2.4		L24		0.30				
2.4.1			L241	0.50				
2.4.2			L242	0.50	1			
3	D1							
3.1		D11		0.10				
3.2		D12		0.45	1	0.33		
3.3		D13		0.45				
4	D2							
4.1		D21		0.05			1	0.32
4.2		D22		0.15				
4.3		D23		0.20	1	0.67		
4.4		D24		0.25				
4.5		D25		0.25				
4.6		D26		0.10				

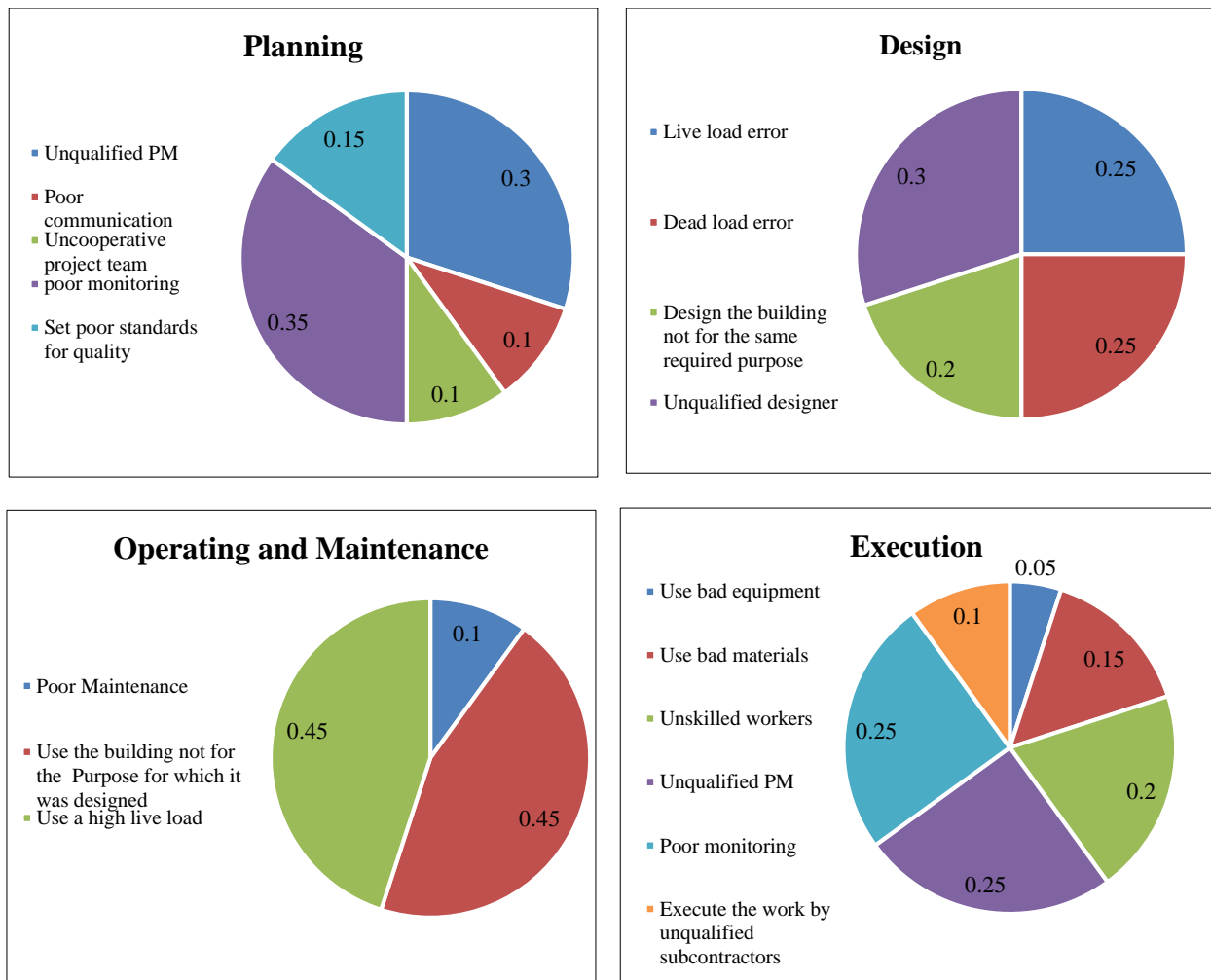

Figure 4. The causes of punching shear

Table 3 shows the risk score (R) for the secondary causes by formula ($R = P \times I$):

Table 3. Probability, impact, and risk score of secondary causes

Current issue	Code of cause	Probability (P)	Impact (I)	Risk score®
1.1	L11	0.30	0.65	0.20
1.2	L12	0.20	0.51	0.10
1.3	L13	0.25	0.45	0.12
1.4	L14	0.55	0.63	0.35
1.5	L15	0.20	0.30	0.06
2.1	L21	0.60	0.75	0.45
2.2	L22	0.33	0.75	0.25
2.3	L23	0.45	0.69	0.31
2.4.1	L241	0.38	0.72	0.28
2.4.2	L242	0.38	0.72	0.28
3.1	D11	0.23	0.44	0.10
3.2	D12	0.55	0.72	0.40
3.3	D13	0.60	0.75	0.45
4.1	D21	0.10	0.25	0.03
4.2	D22	0.65	0.70	0.46

4.3	D23	0.36	0.33	0.12
4.4	D24	0.40	0.52	0.21
4.5	D25	0.62	0.60	0.37
4.6	D26	0.32	0.51	0.17

The risks of main causes are calculated by using the equations mentioned earlier and the weights showed in Table 2 and 3, as follows:

$$R11 = P111 \times R111 + P112 \times R112 + P113 \times R113 + P114 \times R114 + P115 \times R115$$

$$R11 = 0.30 \times 0.20 + 0.10 \times 0.10 + 0.10 \times 0.12 + 0.35 \times 0.35 + 0.15 \times 0.06$$

$$R11 = 0.22$$

$$R124 = P1241 \times R1214 + P1242 \times R1242$$

$$R124 = 0.50 \times 0.28 + 0.50 \times 0.28 = 0.28$$

$$R12 = P121 \times R121 + P122 \times R122 + P123 \times R123 + P124 \times R124$$

$$R12 = 0.25 \times 0.45 + 0.25 \times 0.25 + 0.20 \times 0.31 + 0.30 \times 0.28$$

$$R12 = 0.32$$

And, with the same procedures $Rd1$ and $Rd2$ can be calculated as follows:

$$Rd1 = Pd11 \times Rd11 + Pd12 \times Rd12 + Pd13 \times Rd13$$

$$Rd1 = 0.10 \times 0.10 + 0.45 \times 0.4 + 0.45 \times 0.45$$

$$Rd1 = 0.39$$

$$Rd2 = Pd21 \times Rd21 + Pd22 \times Rd22 + Pd23 \times Rd23 + Pd24 \times Rd24 + Pd25 \times Rd25 + Pd26 \times Rd26$$

$$Rd2 = 0.05 \times 0.03 + 0.15 \times 0.46 + 0.20 \times 0.12 + 0.25 \times 0.21 + 0.25 \times 0.37 + 0.10 \times 0.17$$

$$Rd2 = 0.26$$

Now, we have to determine categories risks on the right and left as follows:

$$Rl = P11 \times R11 + P12 \times R12$$

$$Rl = 0.30 \times 0.22 + 0.70 \times 0.32$$

$$Rl = 0.29$$

$$Rd = Pd1 \times Rd1 + Pd2 \times Rd2$$

$$Rd = 0.33 \times 0.39 + 0.67 \times 0.26$$

$$Rd = 0.30$$

Then, the Global Risk (Punching shear) will be calculated as follows:

$$Rg = Pl \times Rl + Pd \times Rd$$

$$Rg = 0.68 \times 0.29 + 0.32 \times 0.30 = \underline{0.3}$$

Finally, the calculated value of punching shear risk (global risk) must be compared with the established acceptance level by organization.

Assume that the accepted level (Ra) of the punching shear is 0.28 and if:

$Rg < Ra$ — the risk can be neglected and does not require immediate treatment.

If $Rg > Ra$ — the risk must be treated

$Rg = 0.3 > Ra = 0.28$... therefore treatment measure are required.

Table 5. Vulnerabilities table

Current issue	Cause	Code	Risk value	Risk Area
1	Planning	L1	0.22 < 0.28	Neglect
2	Design	L2	0.32 > 0.28	Major (should be treated immediately)
3	Operations & M.	D1	0.39 > 0.28	Major (should be treated immediately)
4	Execution	D2	0.26 < 0.28	Neglect
5	Left Category	R_l	0.29 > 0.28	Major (should be treated immediately)
6	Right Category	R_d	0.30 > 0.28	Major (should be treated immediately)
7	Global Risk	R_g	0.3 > 0.28	Major (should be treated immediately)

7. Conclusion

The project manager should focus on the risk management tool to identify the risks precisely as early as possible and manage those risks throughout the project. Further, to determine the areas of risk, the project should be analyzed, by using one of the risk analysis tools based on the type of the predicted risk. The Fishbone Diagram is one of these tools that can disclose the root cause of the risk events when they occurred or anticipated. However, the Fishbone diagram depends on the correct evaluation of the probability, weight, and impact of the causes. Therefore, it is recommended only for initial or comparative analysis. Additionally, the Fishbone diagram for punching shear's risk elucidated that some of the primary and secondary causes such as planning, designing, and maintenance have values more than the accepted level. Thus, one should concentrate on these areas for adopting the risk response plan for preventing or mitigating these risks.

8. Conflicts of Interest

The authors declare no conflict of interest.

9. References

- [1] A. Rauzana, "Causes of conflicts and disputes in construction projects" Journal of mechanical and civil engineering, vol. 13, pp. 44-48, 2016. doi: 10.9790/1684-1305064448.
- [2] J. Aalto, "Comparison of punching shear design provisions for flat slab" TRITA-BKN. Master Thesis 517, Concrete Structures, June 2017.
- [3] D. D. Shinde, S. Ahirrao, and R. Prasad, "Fishbone diagram: Application to identify the root causes of student-staff problems in technical education" Wireless personal communications, May 2018, Volume 100, Issue 2, pp 653–664. doi: 10.1007/s11277-018-5502-2.
- [4] T. Y. Luo, C. Wu, and L. X. Duan, "Fishbone diagram and risk matrix analysis method and its application in safety assessment of natural gas spherical tank," Journal of Cleaner Production, vol. 174, pp. 296-304, Feb 10 2018. doi: 10.1016/j.jclepro.2017.10.334.
- [5] G. F. Wang "Defect Identification and Quality Control of Steel Structure Installation Projects Based on Fishbone Diagram", Applied Mechanics and Materials, Vol. 340, pp. 104-108, 2013. doi: 10.4028/www.scientific.net/amm.340.104.
- [6] Niu, Dong Xiao, Huan Huan Qiao, Hui Juan Zhai, and Xin Lu. "Power Grid Construction Project Cost Risk Factors Analysis Based on the Fishbone Diagram Theory." Advanced Materials Research 622–623 (December 2012): 1852–1855. doi:10.4028/www.scientific.net/amr.622-623.1852.
- [7] P. Olmati, J. Sagaseta, D. Cormie, and A. E. K. Jones, "Simplified reliability analysis of punching in reinforced concrete flat slab buildings under accidental actions," Engineering Structures, vol. 130, pp. 83-98, Jan 1 2017. doi: 10.1016/j.engstruct.2016.09.061.
- [8] L. F. Hussein "Punching shear behavior of bubble decks under eccentric loads" Master of Science thesis submitted to the University of Baghdad, 2017.
- [9] S. Ericsson and K. Farahaninia, "Punching shear in reinforced concrete slab on edge steel columns" Master of Science thesis in the master's program structural engineering building performance design, 2010.
- [10] B. Belletti, M. Pimentel, M. Scolari, and J. C. Walraven, "Safety assessment of punching shear failure according to the level of approximation approach," Structural Concrete, vol. 16, pp. 366-380, Sep 2015. doi: 10.1002/suco.201500015.
- [11] M. Ju, C. Park, E. S. Hwang, and J. Sim, "Predictability evaluation of the existing punching shear formulas using failure test and probability-based approach," Ksce Journal of Civil Engineering, vol. 19, pp. 1420-1430, Jul 2015. doi: 10.1007/s12205-015-0040-x.
- [12] S. Chandrasekaran, "Offshore structural engineering: reliability and risk assessment: CRC Press, 2016. doi: 10.1201/b21572.